



**MOTO SPORT
PROGRAM**
RACES IN SAFETY

2026-27





MOTO SPORT PROGRAM

RACES IN SAFETY

2026-27



ENG Liski is the leading Italian company in the production of sports equipment and safety equipment for winter and summer disciplines worldwide.

Our passive safety products have been designed, developed and tested by obtaining the homologation of the respective International Federations and resulting in products of absolute excellence; Liski has been present as a leader since the late 1970s in the national and international market of sports equipment supplies, with its 5 production lines:

ITA Liski è l'azienda italiana leader del settore nella produzione di attrezzature sportive e di sicurezza per le discipline invernali ed estive in tutto il mondo.

I nostri prodotti di sicurezza passiva sono stati progettati, sviluppati e testati ottenendo l'omologazione delle rispettive Federazioni Internazionali e risultando prodotti di eccellenza assoluta; Liski è presente come leader dalla fine degli anni '70 nel mercato Nazionale ed Internazionale delle forniture di attrezzature sportive, con le sue 5 Linee di produzione:

WINTER PROGRAM

Protection and Ski slope preparation
Protezione e preparazione delle piste da sci

SUMMER PROGRAM

Play fields equipments
Attrezzature per campi da gioco

MOTO SPORT PROGRAM

Races in Safety
Gare in sicurezza

SKI SERVICE PROGRAM

Repair of ski-snowboard soles
Riparazione di solette per sci e snowboard

BIKE PROGRAM

Road - Bike Park - MTB
Strada - Bike Park - MTB

The company currently puts its structure of consultants, technicians and graphic designers at the disposal of its partners to offer all-round support; its primary aim is to research of increasingly high-performance and safe materials.

To achieve this goal, it makes use of cutting-edge technology and specialised technicians, and of collaboration with experts in all sectors.

The fruitful alliance between technology and human experience has enabled Liski to be constantly present in major sporting competitions worldwide.

L'azienda attualmente mette a disposizione dei partner la propria struttura di consulenti, tecnici e grafici per offrire un supporto a 360 gradi; Il suo scopo primario è la ricerca di materiali sempre più performanti e sicuri.

Per raggiungere questo obiettivo, si avvale di tecnologie d'avanguardia e tecnici specializzati, e della collaborazione con gli addetti ai lavori in tutti i settori.

La proficua alleanza tra tecnologia ed esperienza umana, ha permesso a Liski di essere costantemente presente nelle maggiori competizioni sportive a livello mondiale.

CERTIFICATIONS / CERTIFICAZIONI





LISKI MOTO SPORT PROGRAM

Liski, thanks to its more than forty years experience in the Sport Equipment market, is an Italian Company active on the national and international market as leader in the production of a full range of products for securing ski-slopes, and recently has expanded its range with FIM approved protections for motorcycle circuits.

The protection by LISKI equipment has the main priority the research of high-performance and safe materials, thanks to lead technologies, collaboration with sector experts, and the strict synergy between Universities and specialized Experimental Search Laboratories ensuring the preparation of safety materials, that are subjected to the laboratory crash tests, along with the extensive testing on the field.

Among its most prestigious clients, stand on the Barcelona Catalonia circuit, Valencia circuit and Aragon circuit in Spain, Sepang in Malaysia, Melbourne Phillip Island in Australia, Mugello Misano and Mugello in Italy, Ningbo and Chandu in China.

The products listed in this catalogue are the synthesis of years of competitive spirit, research, technology and passion, real engine of Liski enthusiasm, that here and on the race tell the story of the sport.

Liski, grazie alla sua più che quarantennale esperienza nel settore sportivo, è un'azienda presente sul mercato nazionale e internazionale come leader nella produzione di una vasta gamma di prodotti per la messa in sicurezza di piste da sci, e recentemente ha ampliato la propria gamma con le protezioni omologate FIM per circuiti motociclistici.

La protezione tramite attrezzature Liski ha come obiettivo primario la ricerca di materiali sempre più performanti e sicuri, grazie alla collaborazione con gli addetti ai lavori, e all'impiego di tecnologie d'avanguardia e di tecnici specializzati, che contribuiscono alla messa a punto dei propri materiali. Inoltre, la strettissima e rigorosissima sinergia tra le Università e i Centri Sperimentali di Ricerca altamente qualificati in tutto il mondo, che da sempre accompagna la ricerca Liski, garantisce una totale sicurezza dei materiali, essendo sottoposti alle più estenuanti prove di "crashtest" in laboratorio e poi direttamente sul campo.

Tra i suoi clienti più prestigiosi, spiccano i circuiti di Barcellona Catalogna, Valencia e Aragon in Spagna, Assen in Olanda, Sepang in Malesia, di Phillip Island in Australia, Mugello, Misano e Mugello in Italia, Ningdo e Chandu in Cina.

I prodotti presenti in questo catalogo sono la sintesi di anni di agonismo, ricerca, tecnologia e di passione, vera forza motrice dell'entusiasmo Liski, che qui come in pista racconta la storia dello sport.

Refer to our website www.liski.it for STANDARD TERMS AND CONDITIONS. Liski may change articles materials, dimensions and models of this catalog without notice. The images of the products contained in the catalog may not be perfectly representative of the product's characteristics.

Consultare il sito internet www.liski.it per i TERMINI E LE CONDIZIONI STANDARD DELL'AZIENDA. LISKI si riserva la possibilità di modificare materiali, dimensioni e modelli degli articoli di questo catalogo senza preavviso. Le immagini dei prodotti contenuti nel catalogo potrebbero non essere perfettamente rappresentative delle caratteristiche del prodotto.



Aderente a



CONFINDUSTRIA BERGAMO



Discover the LISKI world!
Scopri il mondo LISKI!

 YouTube







MOTO SPORT PROGRAM

RACES IN SAFETY

2026-27



**MOTO SPORT
PROGRAM**
RACES IN SAFETY 2026-27

INDEX

INDICE

	CRASH TEST and FIM Licenses CRASH TEST e Omologazioni FIM	12
	LISKI AIR SAFETY SYSTEM FIM - TYPE A / AA "Air" stopping barrier FIM - Tipo A / AA "Aria" barriere protettive	14
	LISKI SAFETY 1 FIM - TYPE A "Foam" stopping barrier FIM - Tipo A "Gommapiuma" barriere protettive	16
	LISKI SAFETY 3 FIM - TYPE B stopping barrier FIM - Tipo B barriere protettive	18
	LISKI SAFETY 4 + DOCTOR FIM - TYPE C stopping barrier FIM - Tipo C barriere protettive	20
	Other different mattresses Altri materassi diversi	22
	Motocross safety sistem Sistemi di protezione circuiti motocross	24
	Flags and workforce bibs for race organization Bandiere e pettorine per organizzazione gare	28



IMPACT LABORATORY, Zaragoza - Spain

Crash test

IMPACT LABORATORY ZARAGOZA - SPAIN

Experimental tests conducted in
IMPACT LABORATORY Zaragoza - Spain

TEST SPERIMENTALI ESEGUITI PRESSO
IMPACT LABORATORY DI SARAGOZA - SPAGNA.



Impact Laboratory
Aragon Institute of Engineering Research
University of Zaragoza

DYNAMIC TEST REPORT

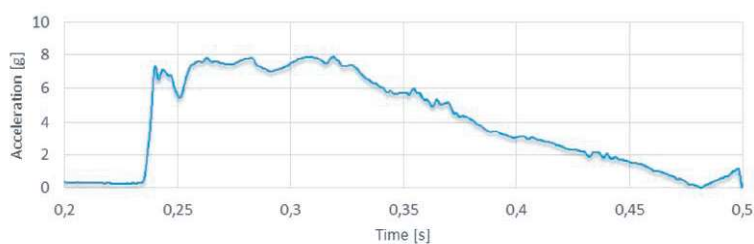

Deceleration Pulse (X Global Axis) - Ref. S-037





FRHPba-01 - 2022

FIM Licenses

INTERNATIONAL MOTORCYCLING FEDERATION CERTIFIED

OMOLOGAZIONI FIM. CERTIFICATI DALLA FEDERAZIONE INTERNAZIONALE MOTOCICLISMO.

LISKI Safety 1

FIM RACING HOMOLOGATION PROGRAMME

CIRCUIT RACING BARRIER

FIM HOMOLOGATION CERTIFICATE

THIS CERTIFICATE GRANTS THE FIM RACING HOMOLOGATION FOR THE FOLLOWING PRODUCT

TRADEMARK	LISKI
MODEL COMMERCIAL NAME	LISKI SAFETY 1
SIZE (L-H-W)	2.5-1.2-1.3/1.2
FIM RACING HOMOLOGATION	FRHPba-01
BARRIER TYPE	CCR - Type A - FRHPba-01
FIM APPLICATION FORM NUMBER(S)	Ba09
TESTING LABORATORY	IMPACT LABORATORY, ALCAÑIZ, SPAIN
TEST REPORT NUMBER(S)	SP2021
TEST REPORT DATE(S)	06/06/2022

MES, 7 June 2022

LISKI Safety 3

FIM RACING HOMOLOGATION PROGRAMME

CIRCUIT RACING BARRIER

FIM HOMOLOGATION CERTIFICATE

THIS CERTIFICATE GRANTS THE FIM RACING HOMOLOGATION FOR THE FOLLOWING PRODUCT

TRADEMARK	LISKI
MODEL COMMERCIAL NAME	LISKI SAFETY 3
SIZE (L-H-W)	2.5-0.6-1.3
FIM RACING HOMOLOGATION	FRHPba-01
BARRIER TYPE	CCR - Type B - FRHPba-01
FIM APPLICATION FORM NUMBER(S)	Ba119
TESTING LABORATORY	IMPACT LABORATORY, ALCAÑIZ, SPAIN
TEST REPORT NUMBER(S)	SP191
TEST REPORT DATE(S)	03/11/2022

MES, 3 November 2022

LISKI Safety 4

FIM RACING HOMOLOGATION PROGRAMME

CIRCUIT RACING BARRIER

FIM HOMOLOGATION CERTIFICATE

THIS CERTIFICATE GRANTS THE FIM RACING HOMOLOGATION FOR THE FOLLOWING PRODUCT

TRADEMARK	LISKI
MODEL COMMERCIAL NAME	LISKI SAFETY 4
SIZE (L-H-W)	2.5-0.3-1.3
FIM RACING HOMOLOGATION	FRHPba-01
BARRIER TYPE	CCR - Type C - FRHPba-01
FIM APPLICATION FORM NUMBER(S)	Ba011
TESTING LABORATORY	IMPACT LABORATORY, ALCAÑIZ, SPAIN
TEST REPORT NUMBER(S)	SP198
TEST REPORT DATE(S)	03/11/2022

MES, 3 November 2022

LISKI AIR SAFETY SYSTEM

FIM - TYPE A / AA "AIR" STOPPING BARRIER



100% FIRE RESISTANT
100% RESISTENTE AL FUOCO

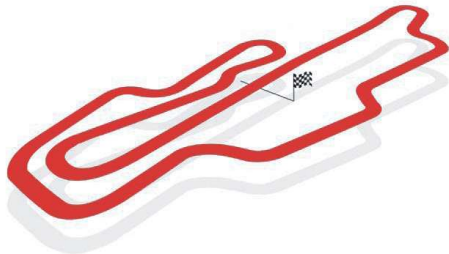

Mugello Circuit - Italy

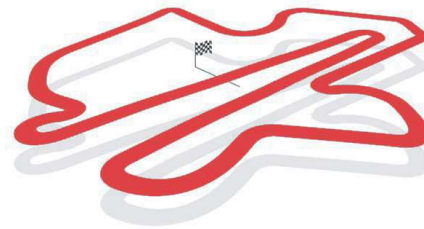

Sepang Circuit - Malaysia



In the aim to provide maximum safety on the track, LISKI offers a wide range of fireproof mattresses, suitable to solve any problem related to security along the circuits. They can be with Air system, or produced in foam rubber 25kg/m³ density and covered in thermo-welded PVC (650 gr/m²) with air vent holes. Last innovation products in the range of LISKI protection equipment, LISKI AIR SAFETY mattress is realized to further improve the safety level in races. Designed by our engineers, is tested by highly qualified laboratories worldwide (Impact Laboratory - Zaragoza), where crash tests are carried out on behalf of the FIM. The protection air system allows the absorption of the pilot's impact in case of a fall, even at high speeds. The mattress is easily anchored by means of a special PVC strip at the base of the structure, and through rear hooks for fixing with ropes.

Nell'ottica di offrire la massima sicurezza in pista, LISKI offre una vasta gamma di materassi ignifughi, idonei a risolvere qualsiasi problema relativo alla protezione lungo i circuiti. Possono essere ad aria o realizzati in gommapiuma densità 25kg/m³ rivestiti in PVC termo-saldato (650 gr/m²) con sfiati d'aria. Fiore all'occhiello della produzione LISKI, sono i materassi LISKI AIR SAFETY; sono stati realizzati per elevare ulteriormente il livello di sicurezza in pista. Studiati dai nostri tecnici, sono testati da personale altamente qualificato in laboratori di livello internazionale (Impact Laboratory - Saragozza) dove vengono effettuati i crash-test per conto della FIM. Il sistema di protezione ad aria permette l'assorbimento dell'urto del pilota in caso di caduta, anche ad alte velocità. Il materasso è facilmente ancorabile mediante apposita striscia di PVC alla base della struttura, e tramite ganci posteriori per il fissaggio con corde.

LISKI AIR SAFETY SYSTEM

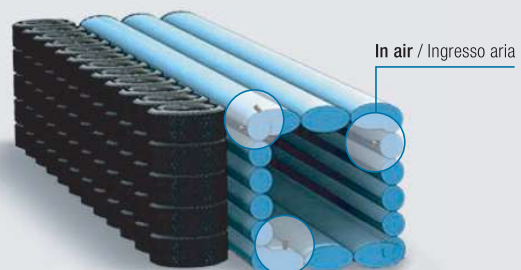

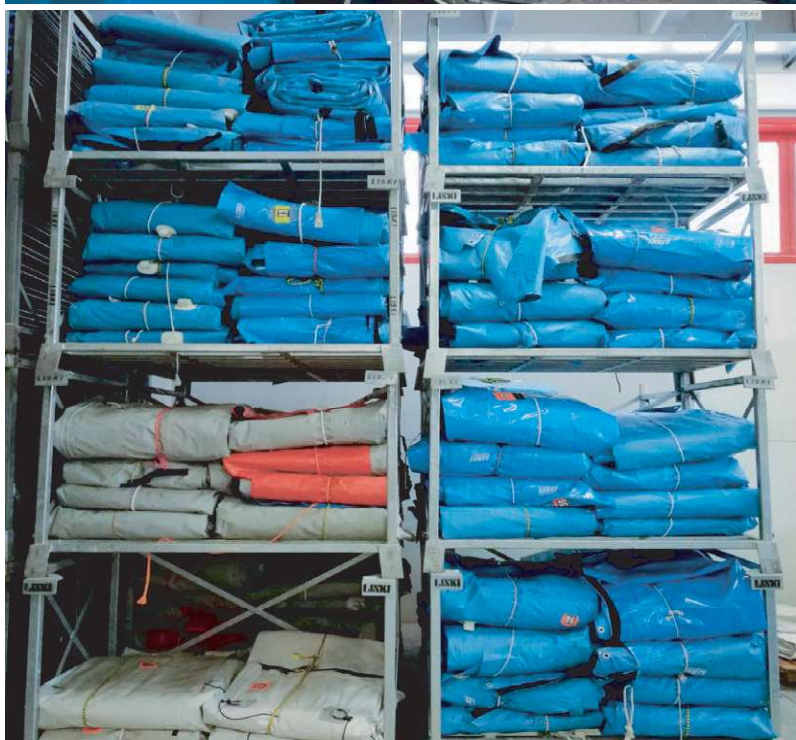

	m ↔	COD.	Classification
Air mattress / Materasso ad aria	8,0 x 1,3 x h 1,3	5-AIR SAFETY	TYPE A "Air"
Air mattress with permanent inflating system Materasso ad aria con sistema di gonfiaggio permanente	8,0 x 1,3 x h 1,3	5-AIR SAFETY + 5-KIT INFLATE	TYPE AA "Air"
Motor blower for air mattress / Soffiante a motore per gonfiaggio materassi ad aria	-	5-12650	-
Electric blower for air mattress / Soffiante elettrica per gonfiaggio materassi ad aria	-	5-12651	-

LISKI SAFETY 1

FIM - TYPE A "FOAM" STOPPING BARRIER



Misano
World Circuit
Marco Simoncelli

LISKI SAFETY 1

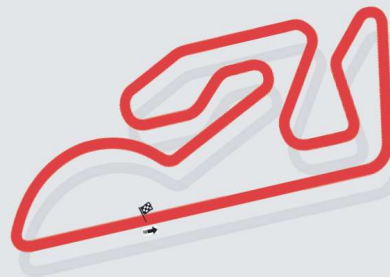
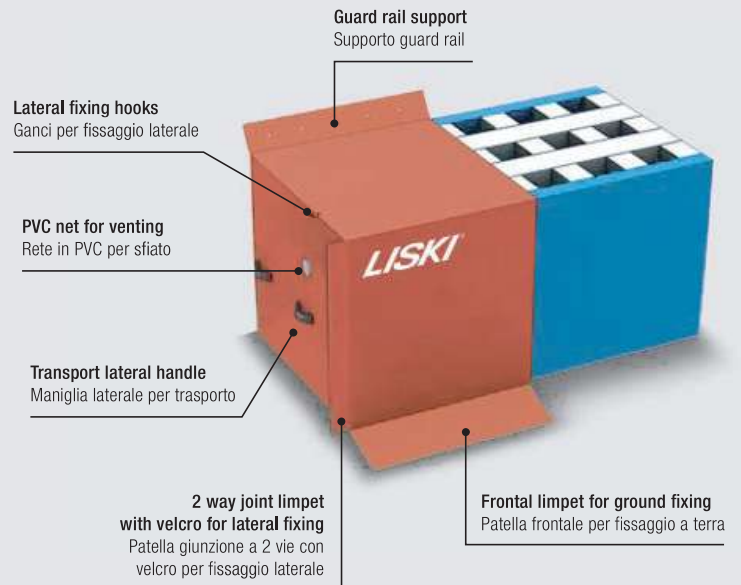

Valencia Circuit - Spain



100% FIRE RESISTANT
100% RESISTENTE AL FUOCO



CUSTOMIZABLE
PERSONALIZZABILI

Technical specifications / Caratteristiche tecniche

100% fire resistant foam rubber mattress 25 kg/m³ density, covered in 100% fire resistant, thermo-welded PVC (650 gr/m²) with air vent holes

Materasso in gommapiuma 100% resistente al fuoco, densità 25 kg/m³ rivestito in PVC termo-saldato (650 gr/m²) 100% resistente al fuoco con sfiati d'aria

m	COD.	Classification
2,5 x 1,2 x h 1,30	5-SAFETY 1 (250)	TYPE A "Foam"

Available colours / Colori disponibili

White / Bianco	Grey2 / Grigio2	Grey3 / Grigio3
Grey1 / Grigio1	Argento / Silver	Beige
Cream / Crema	Ivory / Avorio	Yellow / Giallo
Orange / Arancio	Red / Rosso	Brown / Marrone
Light Blue / Azzurro	Blue1 / Blu1	Blue2 / Blu2
Light Green / Verde chiaro	Green / Verde	Dark Green / Verde scuro



Barcelona-Catalunya Circuit - Spain



Aragon Circuit - Spain



Misano Circuit - Italy

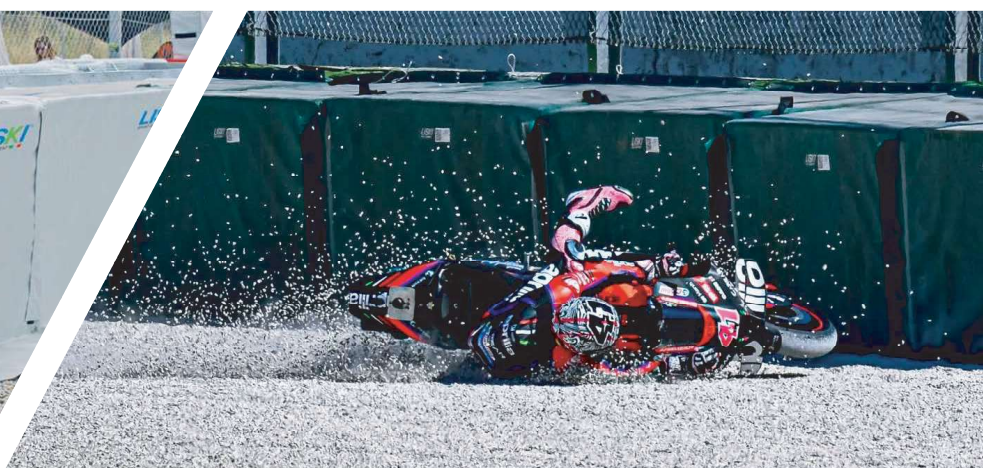

LISKI SAFETY 3

FIM - TYPE B stopping barrier / FIM - Tipo B barriere protettive

LISKI SAFETY 3

FIM - TYPE B STOPPING BARRIER



CUSTOMIZABLE
PERSONALIZZABILI



100% FIRE RESISTANT
100% RESISTENTE AL FUOCO

Technical specifications / Caratteristiche tecniche

100% fire resistant foam rubber mattress 25 kg/m³ density, covered in 100% fire resistant, thermo-welded PVC (650 gr/m²) with air vent holes

Materasso in gommapiuma 100% resistente al fuoco, densità 25 kg/m³ rivestito in PVC termo-saldato (650 gr/m²) 100% resistente al fuoco con sfiati d'aria

 m	COD.	Classification
2,5 x 0,6 x h 1,30	5-SAFETY 3 (250)	TYPE B

Available colours / Colori disponibili

White / Bianco	Grey2 / Grigio2	Grey3 / Grigio3
Grey1 / Grigio1	Argento / Silver	Beige
Cream / Crema	Ivory / Avorio	Yellow / Giallo
Orange / Arancio	Red / Rosso	Brown / Marrone
Light Blue / Azzurro	Blue1 / Blu1	Blue2 / Blu2
Light Green / Verde chiaro	Green / Verde	Dark Green / Verde scuro

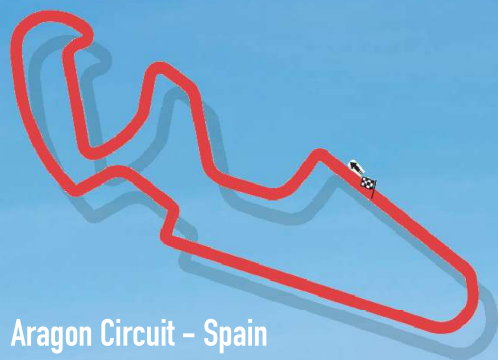

Aragon Circuit - Spain



LISKI SAFETY 3

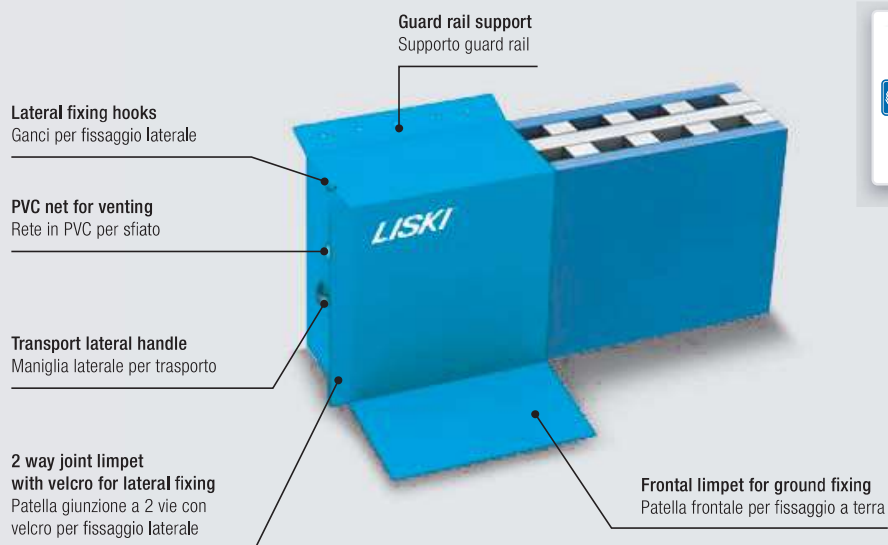

LISKI SAFETY 4 + DOCTOR

FIM - TYPE C stopping barrier / FIM - Tipo C barriere protettive

LISKI SAFETY 4

FIM - TYPE C STOPPING BARRIER



CUSTOMIZABLE
PERSONALIZZABILI



100% FIRE RESISTANT
100% RESISTENTE AL FUOCO



Phillip Island Grand Prix Circuit- Australia

Technical specifications / Caratteristiche tecniche

100% fire resistant foam rubber mattress 25 kg/m³ density, covered in 100% fire resistant, thermo-welded PVC (650 gr/m²) with air vent holes

Materasso in gommapiuma 100% resistente al fuoco, densità 25 kg/m³ rivestito in PVC termo-saldato (650 gr/m²) 100% resistente al fuoco con sfiati d'aria

↔ m	COD.	Classification
2,5 x 0,3 x h 1,30	5-SAFETY 4 (250)	TYPE C

Available colours / Colori disponibili

White / Bianco	Grey2 / Grigio2	Grey3 / Grigio3
Grey1 / Grigio1	Argento / Silver	Beige
Cream / Crema	Ivory / Avorio	Yellow / Giallo
Orange / Arancio	Red / Rosso	Brown / Marrone
Light Blue / Azzurro	Blue1 / Blu1	Blue2 / Blu2
Light Green / Verde chiaro	Green / Verde	Dark Green / Verde scuro



LISKI SAFETY 4

Lateral fixing hooks
Ganci per fissaggio laterale

PVC net for venting
Rete in PVC per sfato

Transport lateral handle
Maniglia laterale per trasporto

2 way joint limpet with velcro for lateral fixing
Patella giunzione a 2 vie con velcro per fissaggio laterale

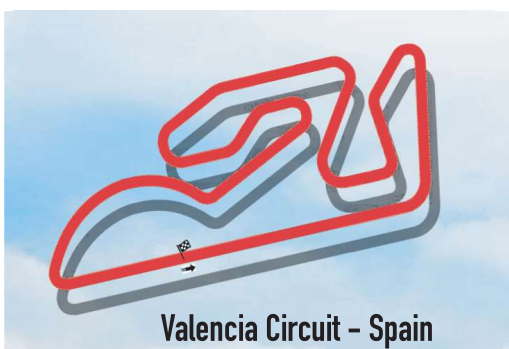
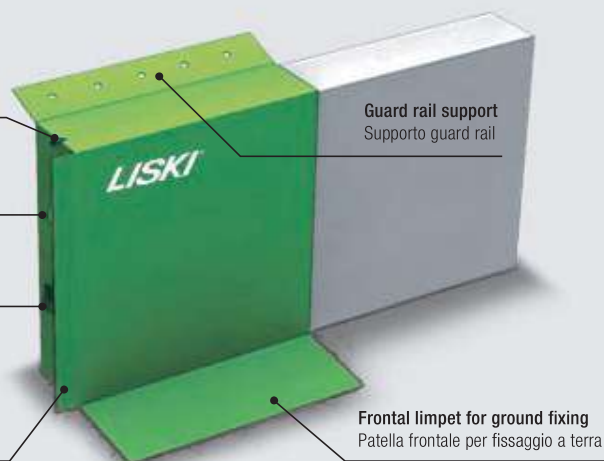

Technical specifications / Caratteristiche tecniche

100% fire resistant foam rubber mattress 25 kg/m³ density, covered in 100% fire resistant, thermo-welded PVC (650 gr/m²) with air vent holes

Materasso in gommapiuma 100% resistente al fuoco, densità 25 kg/m³ rivestito in PVC termo-saldato (650 gr/m²) 100% resistente al fuoco con sfati d'aria

m ↔	COD.	Classification
1,0 x 0,3 x h 0,70	5-MEDICAL	DOCTOR

Other different mattresses

Altri materassi diversi



SPEEDWAY

MATTRESS / MATERASSO

Always in the aim to provide maximum safety on the track, LISKI offers a wide range of mattresses of any size and thickness, suitable to solve any problem related to security along the circuit. Produced in foam rubber 21 kg/m³ density and covered in woven reinforced hot welding PVC, are provided with air vent holes and reflecting strips, and can be customized in any way.

Sempre nell'ottica di offrire la massima sicurezza in pista, LISKI offre una vasta gamma di materassi, di qualsiasi forma, misura e spessore, idonei a risolvere qualsiasi problema relativo alla protezione lungo i circuiti. Realizzati in gommapiuma di densità 21 kg/m³ e rivestiti in PVC termosaldato telato, rinforzato, sono completi di soffiato per sfiato aria e banda rifrangente, e possono essere personalizzati in qualsiasi modo.



Speedway Stadium Ellermühle, Germany





SU RICHIESTA
ON REQUEST



100% FIRE RESISTANT
100% RESISTENTE AL FUOCO

Technical specifications / Caratteristiche tecniche

			cm ↔	COD.
	Foam rubber mattress 30 kg/m³ density, covered in thermo-welded PVC (650 gr/m²) Materasso in gommapiuma densità 30 kg/m ³ rivestiti in PVC termo-saldato (650 gr/m ²)	Color on request Customazible Colore a richiesta Personalizzabile	200 x 130 x th. 15	5-SPEEDWAY
	Foam rubber mattress 30 kg/m³ density, covered in thermo-welded PVC (650 gr/m²), provided with rubber reinforcement kickboard positioned along the length in the lower part of the mattress Materasso in gommapiuma densità 30 kg/m ³ , rivestiti in PVC termo-saldato (650 gr/m ²), dotato di rinforzo anteriore in gomma posizionato sulla lunghezza nella parte inferiore del materasso			5-SPEEDWAY PLUS

"CUSTOM"

CUSTOMIZED MATTRESSES
MATERASSI PERSONALIZZATI

SU RICHIESTA
ON REQUEST



CUSTOMIZABLE
PERSONALIZZABILI



100% FIRE RESISTANT
100% RESISTENTE AL FUOCO



Motocross safety sistem

Sistemi di protezione circuiti motocross



A TIRELESS ELECTRONIC EYE MONITORS THE TRACK.

The Italian company Lightspeed has developed the EYE-TRACK system: the innovative technology that finally allows to reduce the risk of accidents in training and manage the track in the greatest possible safety. EYE-TRACK, the electronic safety system for motocross tracks and for any other motorcycle circuit and racetrack, monitors every blind spot on the track just like a track marshal, every day, at any time, without distraction and at a cheaper price.. And where we talk about safety on the track, we talk about LISKI products; This is how the collaboration was born, and each EYE-TRACK component was integrated with a foam rubber protection covered in tearproof PVC. If a rider loses control of their motorbike, the EYE-TRACK components act as passive protection and absorb the shock.

L'INTELLIGENZA ARTIFICIALE CONTROLLA LA PISTA

L'azienda italiana Lightspeed ha sviluppato il sistema EYE-TRACK: l'innovativa tecnologica che finalmente permette di ridurre il rischio di incidenti in allenamento e gestire la pista nella massima sicurezza possibile. EYE-TRACK, il sistema elettronico di sicurezza per piste di motocross e per ogni altra tipologia di autodromo e motodromo, controlla ogni punto cieco della pista come farebbe un commissario, ma tutti i giorni, a tutte le ore, senza distrarsi, e in modo molto più economico. E dove si parla di sicurezza in pista, si parla di prodotti LISKI; così è nata la collaborazione, ed ad ogni componente EYE-TRACK si è integrata una protezione in gommapiuma ricoperta in PVC antistrappo. Se un pilota perde il controllo del proprio mezzo, le componenti di EYE-TRACK agiscono come protezioni passive assorbendo l'urto.



LISKI[®]
SPORT EQUIPMENT



EYE-TRACK

**WORLDWIDE
MOTOCROSS DISTRIBUTOR**

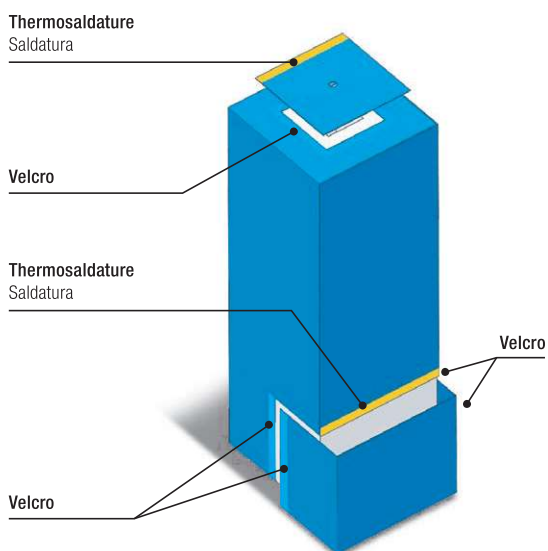
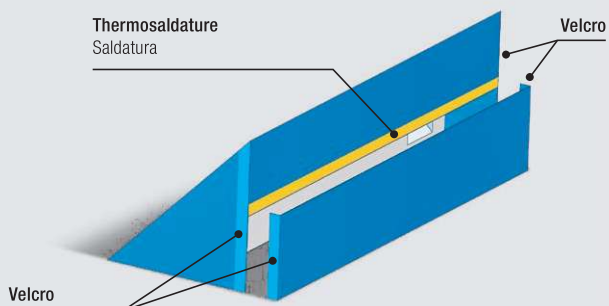

Protection mattresses and safety systems for motocross circuits

Materassi di protezione e sistemi di sicurezza per circuiti di motocross

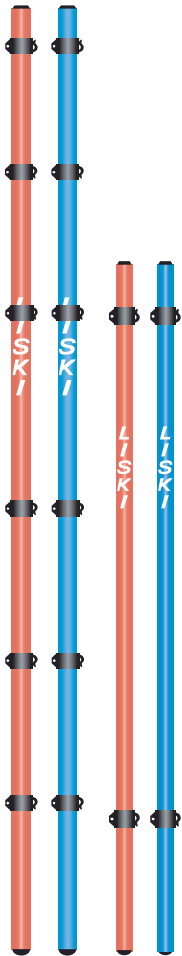

Support pole \varnothing 35 mm x h 250 cm (parabolic curves)

Palo di sostegno \varnothing 35 mm x alt. 250 cm (curve paraboliche)

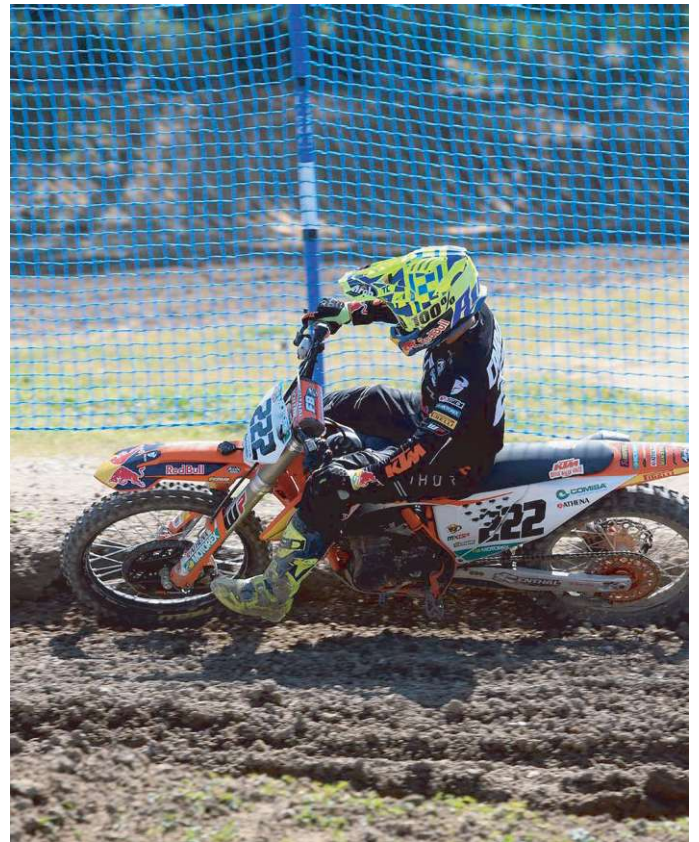

Support pole \varnothing 35 mm x h 165 cm (pre-jumps)

Palo di sostegno \varnothing 35 mm x alt. 165 cm (pre-salti)

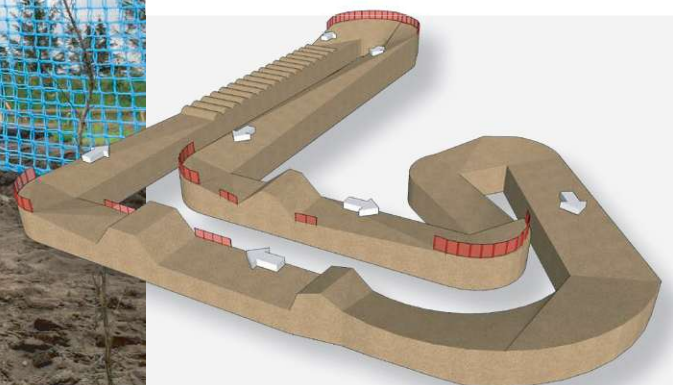

Nets and poles / Reti e pali

		Plait Treccia	Mesh Maglia		COD.
BC-130 net in group 15 m Rete BC-130 in spezzoni da 15 m	15 x h 1,30 m	ø 3,5 mm	5 x 5 cm		12007 G
Pole for BC-130 nets - in polycarbonate, complete with No. 2 adjustable net hooks and conical ferrule Palo per reti BC-130 - in polycarbonato, completo di 2 fascette tendirete regolabili e puntalino conico	ø 35 mm - h 165 cm	n.a.	n.a.		11702
		Plait Treccia	Mesh Maglia		COD.
"Type B" net in high resistance polyethylene hand finished Rete "tipo B" in polietilene alta resistenza finita a mano	15 x h 2 m	ø 3,5 mm	5 x 5 cm		12056G
			7 x 7 cm		12054G
			10 x 10 cm		12052
Pole for "type B" nets in polycarbonate, complete with No. 2 adjustable net hooks Palo per reti "tipo B" in polycarbonato, completo di 2 fascette tendirete regolabili	ø 35 mm - h 250 cm	-	-		11751
Spare net hook for type B pole with super rapid closing Tendirete per pali tipo B con chiusura super rapida	ø 35 mm	-	-		11782/B

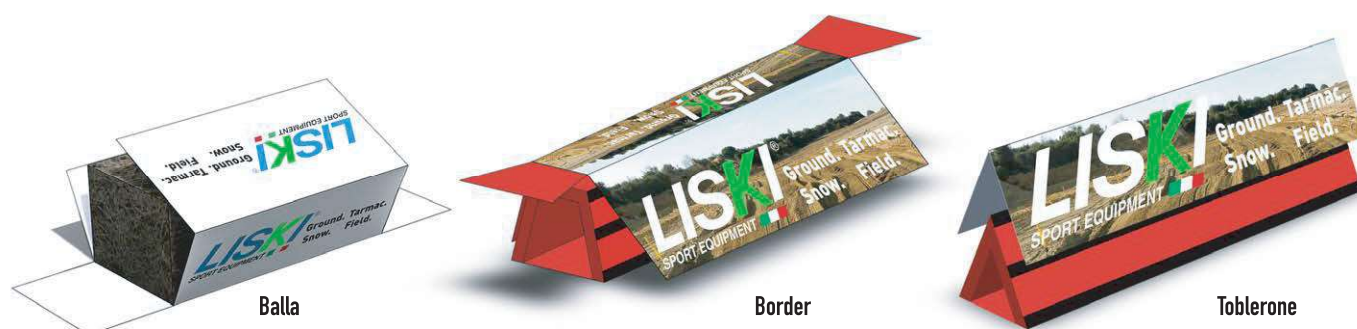

	Material Materiale		cm 	COD.
"Balla" mattress Materasso "Balla"	Foam rubber mattress 21 kg/m³, covered in woven reinforced PVC Gommapiuma densità 21 kg/m ³ , rivestiti in PVC telato rinforzato	Color on request Customizable Colore a richiesta Personalizzabile	130 x h 35 x th. 40	5-Balla21
	Foam rubber mattress 16 kg/m³, covered in woven reinforced PVC Gommapiuma densità 16 kg/m ³ , rivestiti in PVC telato rinforzato			5-Balla16
PVC bag for covering with straw bale Sacco in PVC per rivestimento con balla di paglia	Woven reinforced PVC PVC telato rinforzato		135 x 40 x th. 45	5-Sacco
Triangular "Border" mattress Materasso "Border" triangolare	Foam rubber mattress 21 kg/m³, covered in woven reinforced PVC Gommapiuma densità 21 kg/m ³ , rivestiti in PVC telato rinforzato		200 x h 30 x th. 30	5-Border
Trapezoidal "Toblerone" mattress Materasso "Toblerone" trapezoidale	Gommapiuma densità 21 kg/m ³ , rivestiti in PVC telato rinforzato		200 x h 40 x th. 40/30	5-Toblerone

FLAGS

BANDIERE



Technical specifications / Caratteristiche tecniche

Set of 5 flags 80x100cm in UV resistant polyester, with 100cm pole, for race director / start assistant

Set di 5 bandierine 80x100cm in poliestere resistente ai raggi UV, dotate di asta da 100cm per direttore di gara / assistente alla partenza

COD.

5-KIT FLAG 1



Technical specifications / Caratteristiche tecniche

Set of 6 flags 80x100cm in UV resistant polyester, with 100cm pole, for marshal

Set di 6 bandierine 80x100cm in poliestere resistente ai raggi UV, dotate di asta da 100cm per commissario di percorso

COD.

5-KIT FLAG 2



WORKFORCE BIBS

PETTORINE



Technical specifications / Caratteristiche tecniche

BIB in monoelastic lycra - TRACK SERVICE doubleface - customized	COD.
Coprimaglia / pettorina monoelastica - SERVIZIO PISTA bifacciale / personalizzata	5-13245







IN COLLABORATION WITH

Misano
MWC
World Circuit
Marco Simoncelli

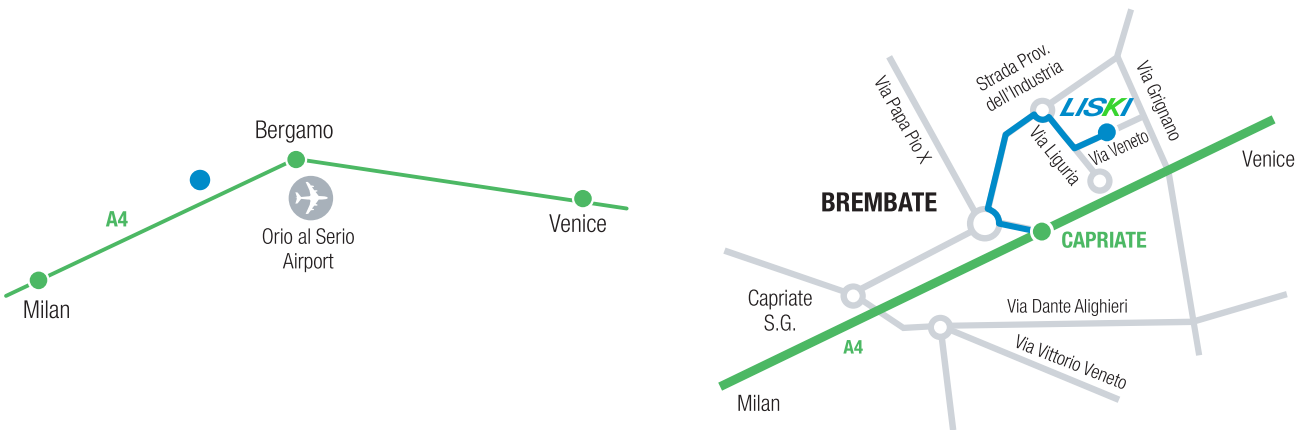
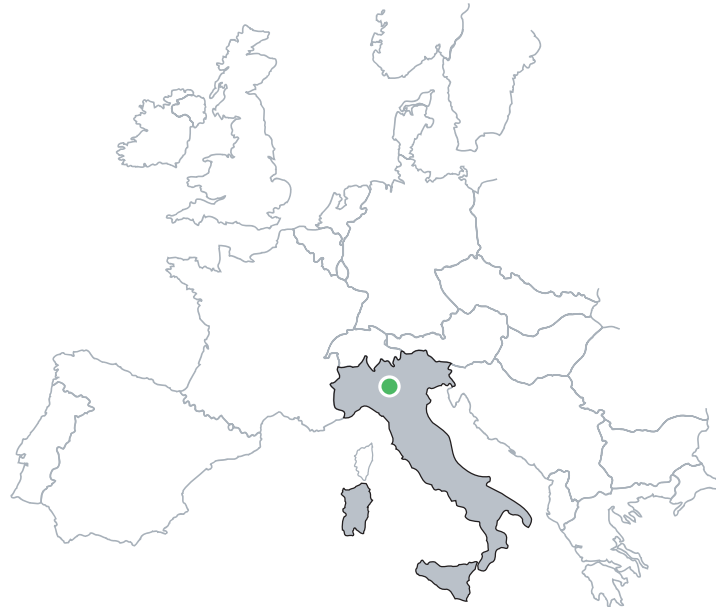

PROUD PARTNER



FRHPba-01 - 2022

IN COLLABORATION WITH



MOTOCROSS WORLDWIDE DISTRIBUTOR



LISKI srl
 Via Veneto, 8 - 24041 Brembate (BG) - ITALY
 Ph. +39 035 4826195 - Fax +39 035 2283818
 info@liski.it - liski@pec.it -

